

**DV213**  
**Tier 3**  
Vibratory Roller

**SERVICE MANUAL**

**Part number 47703722**  
2<sup>nd</sup> edition English  
September 2015  
*Replaces part number 84287246A*





# **SERVICE MANUAL**

**DV213**

# Contents

---

## INTRODUCTION

Machine completion and equipment.....	05
[05.102] Machine completion.....	05.1
Engine.....	10
[10.001] Engine and crankcase.....	10.1
[10.400] Engine cooling system.....	10.2
Hydrostatic drive.....	29
[29.218] Pump and motor components.....	29.1
Hydraulic systems.....	35
[35.000] Hydraulic systems.....	35.1
[35.353] Hydraulic travel system.....	35.2
[35.995] Compaction/vibration hydraulic system.....	35.3
[35.500] Radiator cleaning system.....	35.4
[35.304] Combination pump units.....	35.5
Frames and ballasting.....	39
[39.500] Vibratory roller.....	39.1
[39.100] Frame.....	39.2
Steering.....	41
[41.101] Steering control.....	41.1
[41.206] Pump.....	41.2
[41.216] Cylinders.....	41.3
Wheels.....	44
[44.160] Compaction drums.....	44.1
Cab climate control.....	50
[50.100] Heating.....	50.1

<b>Electrical systems .....</b>	<b>55</b>
[55.000] Electrical system .....	55.1
[55.100] Harnesses and connectors.....	55.2
[55.201] Engine starting system .....	55.3
[55.301] Alternator.....	55.4
[55.302] Battery.....	55.5
[55.408] Warning indicators, alarms, and instruments .....	55.6
[55.019] Hydrostatic drive control system .....	55.7
[55.050] Heating, Ventilation, and Air-Conditioning (HVAC) control system.....	55.8
[55.518] Wiper and washer system.....	55.9
[55.512] Cab controls.....	55.10
<b>Platform, cab, bodywork, and decals .....</b>	<b>90</b>
[90.120] Mechanically-adjusted operator seat.....	90.1
[90.105] Machine shields and guards .....	90.2

**Thanks very much for your reading,  
Want to get more information,  
Please click here, Then get the complete  
manual**

**JustClickHere** 

**NOTE:**

**If there is no response to click on the link above,  
please download the PDF document first, and then  
click on it.**

**Have any questions please write to me:  
[admin@servicemanualperfect.com](mailto:admin@servicemanualperfect.com)**





## **INTRODUCTION**

# Contents

---

## INTRODUCTION

Foreword - Important notice regarding equipment servicing .....	3
Safety rules .....	4
Safety rules .....	5
Safety rules .....	7
Safety rules - Ecology and the environment .....	10
Safety rules - Shop and assembly .....	11
Safety rules – Hydraulic contamination .....	13
Personal safety .....	14
Torque .....	15
Special tools .....	18
Hydraulic contamination – Contamination .....	21
Consumables .....	22
Product identification .....	27
Product identification .....	28



---

## **Foreword - Important notice regarding equipment servicing**

All repair and maintenance work listed in this manual must be carried out only by qualified dealership personnel, strictly complying with the instructions given, and using, whenever possible, the special tools.

Anyone who performs repair and maintenance operations without complying with the procedures provided herein shall be responsible for any subsequent damages.

The manufacturer and all the organizations of its distribution chain, including - without limitation - national, regional, or local dealers, reject any responsibility for damages caused by parts and/or components not approved by the manufacturer, including those used for the servicing or repair of the product manufactured or marketed by the manufacturer. In any case, no warranty is given or attributed on the product manufactured or marketed by the manufacturer in case of damages caused by parts and/or components not approved by the manufacturer.

The manufacturer reserves the right to make improvements in design and changes in specifications at any time without notice and without incurring any obligation to install them on units previously sold. Specifications, descriptions, and illustrative material herein are as accurate as known at time of publication but are subject to change without notice.

In case of questions, refer to your CASE CONSTRUCTION Sales and Service Networks.

## Safety rules

### Personal safety





This is the safety alert symbol. It is used to alert you to potential personal injury hazards. Obey all safety messages that follow this symbol to avoid possible death or injury.

Throughout this manual you will find the signal words **DANGER**, **WARNING**, and **CAUTION** followed by special instructions. These precautions are intended for the personal safety of you and those working with you.

Read and understand all the safety messages in this manual before you operate or service the machine.

 **DANGER** indicates a hazardous situation that, if not avoided, will result in death or serious injury.

 **WARNING** indicates a hazardous situation that, if not avoided, could result in death or serious injury.

 **CAUTION** indicates a hazardous situation that, if not avoided, could result in minor or moderate injury.

**FAILURE TO FOLLOW DANGER, WARNING, AND CAUTION MESSAGES COULD RESULT IN DEATH OR SERIOUS INJURY.**

### Machine safety

**NOTICE:** *Notice indicates a situation that, if not avoided, could result in machine or property damage.*

Throughout this manual you will find the signal word **Notice** followed by special instructions to prevent machine or property damage. The word **Notice** is used to address practices not related to personal safety.

### Information

**NOTE:** *Note indicates additional information that clarifies steps, procedures, or other information in this manual.*

Throughout this manual you will find the word **Note** followed by additional information about a step, procedure, or other information in the manual. The word **Note** is not intended to address personal safety or property damage.

## Safety rules

Carefully read the safety rules contained herein and follow advised precautions to avoid potential hazards and to safeguard your safety and personal integrity.

Your safety and that of the people around you depends on you.

It is essential that you understand this manual for a correct inspection, lubrication and repair of this machine.

Read this manual carefully and check that:

- You understand fully the symbols on the controls and the safety signs used in this manual and on the machine.
- You understand fully the speed, stability, braking and steering characteristics of the machine. If you are in any doubt, consult your Dealer.

The safety messages in this section concern situations which may arise during normal machine operation, servicing and repair. These safety messages also indicate the different ways of coping with these situations. Other safety messages are used throughout the manual to indicate specific dangers.

The information given in this chapter is a summary of the basic rules to respect at all times and does not exempt you from observing traffic regulations or the requirements of insurance companies.

The presence of grease, oil, mud or (in winter) ice on the steps and access handles can cause accidents. Make sure they are always clean.

When mounting or dismounting from the machine always face the machine and use the steps and access handles on the left-hand side of the machine.

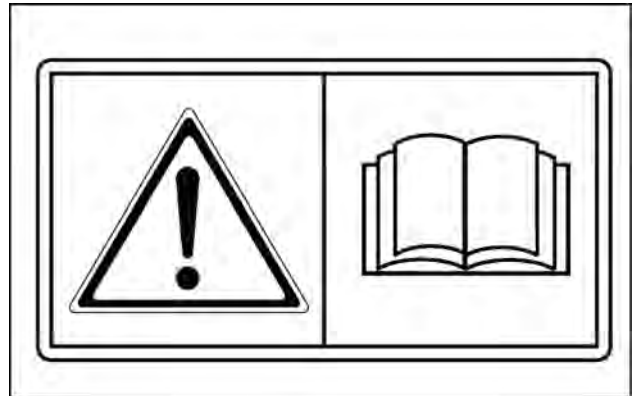

LELI12TLB0048AB 1

Wear close fitting clothing and safety equipment appropriate for the job:

- Safety helmet
- Safety shoes
- Heavy gloves
- Reflective clothing
- Wet weather clothing

If the environment conditions make it necessary, the following personal safety equipment should be at hand:

- Respirators (or dustproof masks)
- Ear plugs or acoustic ears protections
- Goggles with lateral shield or masks for eyes protection

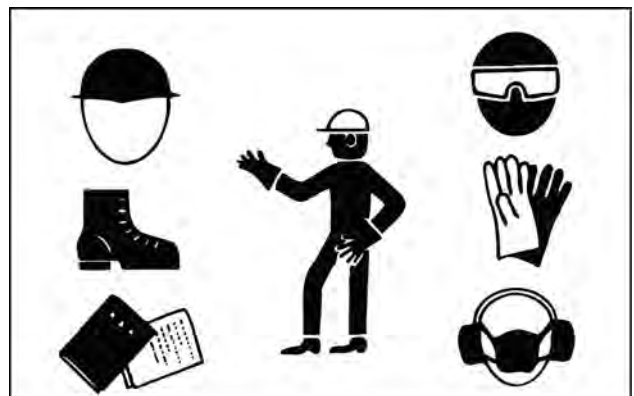

LELI12TLB0049AB 2

Do not wear rings, wristwatches, jewels, unbuttoned or flapping clothing such as ties, torn clothes, scarves, open jackets or shirts with open zips which could get caught into moving parts.

Any functional disorders, especially those affecting the safety of the machine, should therefore be rectified immediately.

## INTRODUCTION

Make sure that you fully understand the symbols of the safety decals applied on the machine. Make sure that they are always clean and perfectly legible.

Be prepared for emergencies.

Always keep a first aid kit and a fire extinguisher close at hand on the machine.

Make sure that the fire extinguisher is serviced in accordance with the manufacturer's instructions.

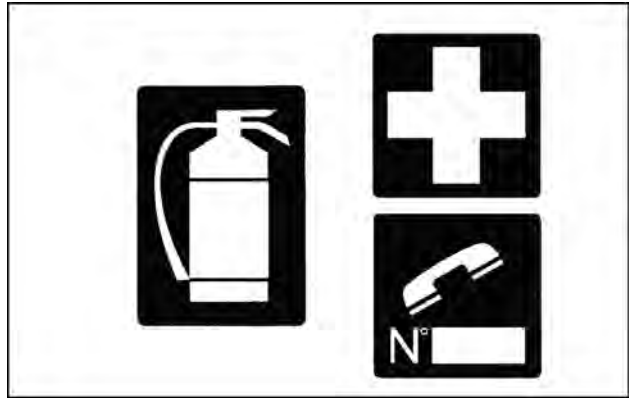

LEL112TLB0050AB 3

## Safety rules

### Prevention of fire or explosions

The engine fuel can originate an explosion or a fire.

Never refuel when the engine is running.

Do not smoke during refuelling.

Take all the necessary safety measures when welding, grinding or when working near a naked flame.

Use a non-flammable product for cleaning parts.



LEL112TLB0051AA 1

A spark or a flame can cause the electrolyte of the battery to explode.

To prevent any risk of explosion, observe the following instructions:

- When disconnecting the battery cables, always disconnect the negative (-) cable first.
- To reconnect the battery cables, always connect the negative (-) cable last.
- Never short-circuit the battery clamps with metal objects.
- Do not weld, grind or smoke near a battery.

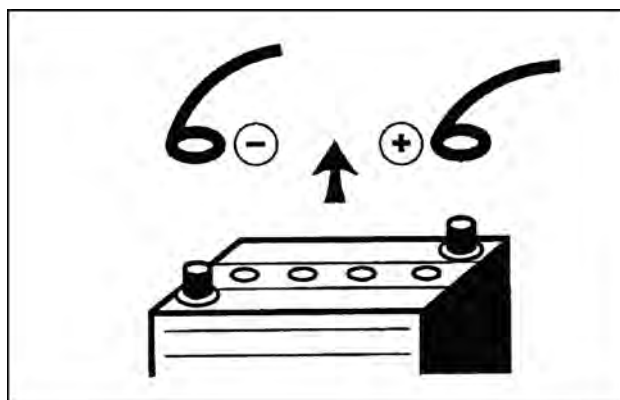

LEL112TLB0052AA 2

The engine exhaust may produce sparks.

Before using the machine in an area which may contain inflammable vapours, ensure that there is good ventilation.

Always keep a fire extinguisher available on the machine.

Make sure that it is properly maintained in conformity with the manufacturer's instructions.

## Prevention of burns

The battery electrolyte generates severe burns.

The battery contains sulphuric acid.

Avoid any contact with the skin, eyes or clothing.

Antidote:

- EXTERNAL: Rinse well with water, removing any soiled clothing.
- INTERNAL: Avoid vomiting. Drink water to rinse your mouth. Consult a doctor.
- EYES: Rinse thoroughly with water for **15 min** and get prompt medical attention.

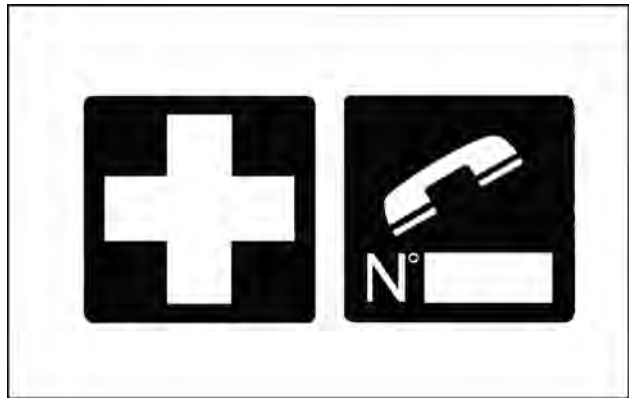

LEL112TLB0053AA 3

When the electrolyte of a battery is frozen, it can explode if you attempt to charge the battery or if you try to start the engine using a booster battery.

Always keep the battery charged to prevent the electrolyte freezing.

Batteries generate explosive gases.

Keep all flames, sparks and cigarettes away.

Provide good ventilation when changing a battery or using a battery in an enclosed space.

Always protect your eyes when working near a battery.

Never touch the battery terminals with your hands.

This can induce a state of electrolysis and impair the main organs of the body.



LEL112TLB0054AA 4

Hot coolant could spray out if the radiator cap is removed while the system is still hot.

To remove the cap: Allow the system to cool down, turn the cap to the first notch and wait until there is no more pressure.

Then remove the cap.



LEL112TLB0055AA 5

## Precautions for waste disposal

Improperly disposing of waste can threaten the environment.

Each country has its own Regulations on this subject. It is therefore advisable to prepare suitable containers to collect and store momentarily all solid and fluid materials that must not be scattered in the environment to avoid pollution.

At preset intervals these products will be delivered to disposal stations legally recognized and present in this Country.

Here below is a list of the products in the machine which require disposal:

- Hydraulic oil
- Brake system oil
- Coolant mixture, condensation residue and pure anti-freeze
- Diesel oil
- Oil and diesel oil filter elements
- Engine and air-conditioning air filter elements
- Battery

Also polluting rags, paper, sawdust and gloves must be disposed in compliance with the same procedures.

Do not use food or beverage containers that may mislead someone into drinking from them.

Do not pour waste onto the ground, down a drain, or into any water source.

Air-conditioning coolant escaping into the air can damage the Earth's atmosphere.

Government regulations may require a certified air-conditioning service centre to recover and recycle used air-conditioning coolant.

Obtain information on the proper way to recycle or dispose of waste from your local environmental or recycling centre, or from your Dealer.

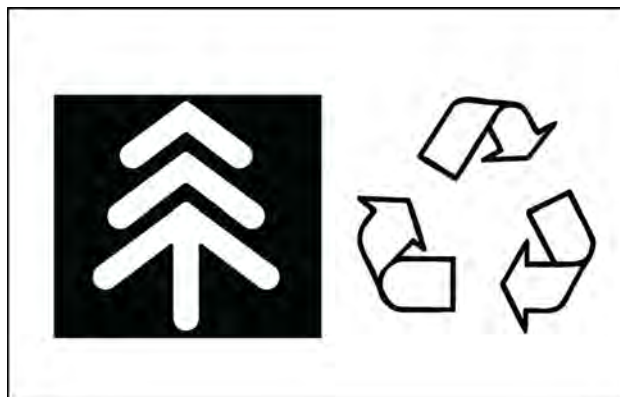

LEL112TLB0056AA 6

---

## Safety rules - Ecology and the environment

Soil, air, and water quality is important for all industries and life in general. When legislation does not yet rule the treatment of some of the substances that advanced technology requires, sound judgment should govern the use and disposal of products of a chemical and petrochemical nature.

Familiarize yourself with the relative legislation applicable to your country, and make sure that you understand this legislation. Where no legislation exists, obtain information from suppliers of oils, filters, batteries, fuels, anti-freeze, cleaning agents, etc., with regard to the effect of these substances on man and nature and how to safely store, use, and dispose of these substances.

### Helpful hints

- Avoid the use of cans or other inappropriate pressurized fuel delivery systems to fill tanks. Such delivery systems may cause considerable spillage.
- In general, avoid skin contact with all fuels, oils, acids, solvents, etc. Most of these products contain substances that may be harmful to your health.
- Modern oils contain additives. Do not burn contaminated fuels and or waste oils in ordinary heating systems.
- Avoid spillage when you drain fluids such as used engine coolant mixtures, engine oil, hydraulic fluid, brake fluid, etc. Do not mix drained brake fluids or fuels with lubricants. Store all drained fluids safely until you can dispose of the fluids in a proper way that complies with all local legislation and available resources.
- Do not allow coolant mixtures to get into the soil. Collect and dispose of coolant mixtures properly.
- The air-conditioning system contains gases that should not be released into the atmosphere. Consult an air-conditioning specialist or use a special extractor to recharge the system properly.
- Repair any leaks or defects in the engine cooling system or hydraulic system immediately.
- Do not increase the pressure in a pressurized circuit as this may lead to a component failure.
- Protect hoses during welding. Penetrating weld splatter may burn a hole or weaken hoses, allowing the loss of oils, coolant, etc.

### Battery recycling

Batteries and electric accumulators contain several substances that can have a harmful effect on the environment if the batteries are not properly recycled after use. Improper disposal of batteries can contaminate the soil, groundwater, and waterways. CASE CONSTRUCTION strongly recommends that you return all used batteries to a CASE CONSTRUCTION dealer, who will dispose of the used batteries or recycle the used batteries properly. In some countries, this is a legal requirement.



### Mandatory battery recycling

**NOTE:** *The following requirements are mandatory in Brazil.*

Batteries are made of lead plates and a sulfuric acid solution. Because batteries contain heavy metals such as lead, CONAMA Resolution 401/2008 requires you to return all used batteries to the battery dealer when you replace any batteries. Do not dispose of batteries in your household garbage.

Points of sale are obliged to:

- Accept the return of your used batteries
- Store the returned batteries in a suitable location
- Send the returned batteries to the battery manufacturer for recycling



## **Safety rules - Shop and assembly**

### **O-ring seals**

Lubricate the O-ring seals before you insert them in the seats. This will prevent the O-ring seals from overturning and twisting, which would jeopardize sealing efficiency.

### **Sealing compounds**

Apply a sealing compound on the mating surfaces when specified by the procedure. Before you apply the sealing compound, prepare the surfaces as directed by the product container.

### **Spare parts**

Only use CNH Original Parts.

Only genuine spare parts guarantee the same quality, duration, and safety as original parts, as they are the same parts that are assembled during standard production. Only CNH Original Parts can offer this guarantee.

When ordering spare parts, always provide the following information:

- Machine model (commercial name) and Product Identification Number (PIN)
- Part number of the ordered part, which can be found in the parts catalog

---

## Protecting the electronic and/or electrical systems during charging and welding

To avoid damage to the electronic and/or electrical systems, always observe the following practices:

1. Never make or break any of the charging circuit connections when the engine is running, including the battery connections.
2. Never short any of the charging components to ground.
3. Always disconnect the ground cable from the battery before arc welding on the machine or on any machine attachment.
  - Position the welder ground clamp as close to the welding area as possible.
  - If you weld in close proximity to a computer module, then you should remove the module from the machine.
  - Never allow welding cables to lie on, near, or across any electrical wiring or electronic component while you weld.
4. Always disconnect the negative cable from the battery when charging the battery in the machine with a battery charger.

**NOTICE:** *If you must weld on the unit, you must disconnect the battery ground cable from the machine battery. The electronic monitoring system and charging system will be damaged if this is not done.*

5. Remove the battery ground cable. Reconnect the cable when you complete welding.

### **WARNING**

**Battery acid causes burns. Batteries contain sulfuric acid.**

**Avoid contact with skin, eyes or clothing. Antidote (external): Flush with water. Antidote (eyes): flush with water for 15 minutes and seek medical attention immediately. Antidote (internal): Drink large quantities of water or milk. Do not induce vomiting. Seek medical attention immediately.**

**Failure to comply could result in death or serious injury.**

W0111A

## Special tools

The special tools that CASE CONSTRUCTION suggests and illustrate in this manual have been specifically researched and designed for use with CASE CONSTRUCTION machines. The special tools are essential for reliable repair operations. The special tools are accurately built and rigorously tested to offer efficient and long-lasting operation.

By using these tools, repair personnel will benefit from:

- Operating in optimal technical conditions
- Obtaining the best results
- Saving time and effort
- Working in safe conditions

---

## Safety rules – Hydraulic contamination

Contamination in the hydraulic system is a major cause of the malfunction of hydraulic components. Contamination is any foreign material in the hydraulic oil.

Contamination can enter the hydraulic system in several ways:

- When you drain the oil or disconnect any line
- When you disassemble a component
- From normal wear of the hydraulic components
- From damaged seals or worn seals
- From a damaged component in the hydraulic system

All hydraulic systems operate with some contamination. The design of the components in this hydraulic system permits efficient operation with a small amount of contamination. An increase in this amount of contamination can cause problems in the hydraulic system.

The following list includes some of these problems:

- Cylinder rod seals that leak
- Hydraulic oil that becomes too hot
- Pump gears, housing, and other parts that wear rapidly
- Relief valves or check valves held open by dirt
- Quick failure of components that have been repaired
- The machine does not have enough power.

If your machine has any of these problems, check the hydraulic oil for contamination.

There are two types of contamination: microscopic and visible.

Microscopic contamination occurs when very fine particles of foreign material are suspended in the hydraulic oil. These particles are too small to see or feel. Microscopic contamination can be found by identification of the following problems or by testing in a laboratory.

Examples of problems caused by microscopic contamination:

- Cylinder rod seals that leak
- The hydraulic system has a high operating temperature

Visible contamination is foreign material that can be found by sight, touch, or odor. Visible contamination can cause a sudden failure of components.

Examples of problems caused by visible contamination:

- Particles of metal or dirt in the oil
- Air in the oil
- Dark or thick oil
- Oil with an odor of burned oil
- Water in the oil

If you find contamination, use a portable filter to clean the hydraulic system.

## Personal safety

Wear Personal Protective Equipment (PPE) such as hard hat, eye protection, heavy gloves, hearing protection, protective clothing, etc.

Wear working footwear with non-slip soles. Smooth soles may slip from steps and pedals resulting in injury or incorrect operation.

Wear closely fitting work clothes when operating the machine. Loose, wide garments may result in the control lever being inadvertently activated.

Keep clear of moving parts. Loose clothing, jewelry, watches, long hair, and other loose or hanging items can become entangled in moving parts.

Do not smoke or use an open flame when at work.

Always wear eye protection when working with batteries.

Do not create sparks or have an open flame near the battery.

Hydraulic oil or diesel fuel leaking under pressure can penetrate the skin, causing serious injury or infection.

- Do not use your hand to check for leaks. Use a piece of cardboard or paper.
- Stop engine, remove key and relieve the pressure before connecting or disconnecting fluid lines.
- Make sure all components are in good condition and tighten all connections before starting the engine or pressurizing the system.
- If hydraulic fluid or diesel penetrates the skin, seek medical attention immediately.
- Continuous long term contact with hydraulic fluid may cause skin cancer. Avoid long term contact and wash the skin promptly with soap and water.

## Torque

- Confirm regularly that bolted connections have not come loose.
- Use torque wrenches for tightening.
- If a special torque is needed, it is mentioned in the section.

Thread size	TIGHTENING TORQUE	
	For screws 8.8 (8G)	For screws 10.9 (10K)
M6	10 N·m (7.4 lb ft)	14 N·m (10.3 lb ft)
M8	24 N·m (17.7 lb ft)	34 N·m (25.1 lb ft)
M8x1	19 N·m (14.0 lb ft)	27 N·m (19.9 lb ft)
M10	48 N·m (35.4 lb ft)	67 N·m (49.4 lb ft)
M10x1.25	38 N·m (28.0 lb ft)	54 N·m (39.8 lb ft)
M12	83 N·m (61.2 lb ft)	117 N·m (86.3 lb ft)
M12x1.25	66 N·m (48.7 lb ft)	94 N·m (69.3 lb ft)
M14	132 N·m (97.4 lb ft)	185 N·m (136.4 lb ft)
M14x1.5	106 N·m (78.2 lb ft)	148 N·m (109.2 lb ft)
M16	200 N·m (147.5 lb ft)	285 N·m (210.2 lb ft)
M16x1.5	160 N·m (118.0 lb ft)	228 N·m (168.2 lb ft)
M18	275 N·m (202.8 lb ft)	390 N·m (287.6 lb ft)
M18x1.5	220 N·m (162.3 lb ft)	312 N·m (230.1 lb ft)
M20	390 N·m (287.6 lb ft)	550 N·m (405.6 lb ft)
M20x1.5	312 N·m (230.1 lb ft)	440 N·m (324.5 lb ft)
M22	530 N·m (390.9 lb ft)	745 N·m (549.5 lb ft)
M22x1.5	425 N·m (313.5 lb ft)	590 N·m (435.2 lb ft)
M24	675 N·m (497.9 lb ft)	950 N·m (700.7 lb ft)
M24x2	540 N·m (398.3 lb ft)	760 N·m (560.5 lb ft)
M27	995 N·m (733.9 lb ft)	1400 N·m (1032.6 lb ft)
M27x2	795 N·m (586.4 lb ft)	1120 N·m (826.0 lb ft)
M30	1350 N·m (995.7 lb ft)	1900 N·m (1401.4 lb ft)
M30x2	1080 N·m (796.6 lb ft)	1520 N·m (1121.1 lb ft)

The values given in the table are torques at dry thread (at coefficient of friction = 0.14). These values do not apply to greased thread.

Table with torques of cap nuts with O-ring - hoses

Size wrench	Thread size	Hose	Tightening torques for cap nuts with O-ring - hoses		
			Nominal	Min	Max
14	12x1.5	6	20 N·m (14.8 lb ft)	15 N·m (11.1 lb ft)	25 N·m (18.4 lb ft)
17	14x1.5	8	38 N·m (28.0 lb ft)	30 N·m (22.1 lb ft)	45 N·m (33.2 lb ft)
19	16x1.5	8	45 N·m (33.2 lb ft)	38 N·m (28.0 lb ft)	52 N·m (38.4 lb ft)
		10			
22	18x1.5	10	51 N·m (37.6 lb ft)	43 N·m (31.7 lb ft)	58 N·m (42.8 lb ft)
		12			
24	20x1.5	12	58 N·m (42.8 lb ft)	50 N·m (36.9 lb ft)	65 N·m (47.9 lb ft)
27	22x1.5	14	74 N·m (54.6 lb ft)	60 N·m (44.3 lb ft)	88 N·m (64.9 lb ft)
		15			
30	24x1.5	16	74 N·m (54.6 lb ft)	60 N·m (44.3 lb ft)	88 N·m (64.9 lb ft)
32	26x1.5	18	105 N·m (77.4 lb ft)	85 N·m (62.7 lb ft)	125 N·m (92.2 lb ft)

INTRODUCTION

			Tightening torques for cap nuts with O-ring - hoses		
Size wrench	Thread size	Hose	Nominal	Min	Max
36	30x2	20	135 N·m (99.6 lb ft)	115 N·m (84.8 lb ft)	155 N·m (114.3 lb ft)
		22			
41	36x2	25	166 N·m (122.4 lb ft)	140 N·m (103.3 lb ft)	192 N·m (141.6 lb ft)
46		28			
50	42x2	30	240 N·m (177.0 lb ft)	210 N·m (154.9 lb ft)	270 N·m (199.1 lb ft)
50	45x2	35	290 N·m (213.9 lb ft)	255 N·m (188.1 lb ft)	325 N·m (239.7 lb ft)
		38	330 N·m (243.4 lb ft)	280 N·m (206.5 lb ft)	380 N·m (280.3 lb ft)
	42				

Table for torques of necks with sealing edge or with flat gasket

G - M	Tightening torques for flanges
G 1/8	25 N·m (18 lb ft)
G1/4	40 N·m (30 lb ft)
G 3/8	95 N·m (70 lb ft)
G 1/2	130 N·m (96 lb ft)
G 3/4	250 N·m (184 lb ft)
G 1	400 N·m (295 lb ft)
G 1 1/4	600 N·m (443 lb ft)
G 1 1/2	800 N·m (590 lb ft)
10 x 1	25 N·m (18 lb ft)
12 x 1.5	30 N·m (22 lb ft)
14 x 1.5	50 N·m (37 lb ft)
16 x 1.5	60 N·m (44 lb ft)
18 x 1.5	60 N·m (44 lb ft)
20 x 1.5	140 N·m (103 lb ft)
22 x 1.5	140 N·m (103 lb ft)
26 x 1.5	220 N·m (162 lb ft)
27 x 1.5	250 N·m (184 lb ft)
33 x 1.5	400 N·m (295 lb ft)
42 x 1.5	600 N·m (443 lb ft)
48 x 1.5	800 N·m (590 lb ft)

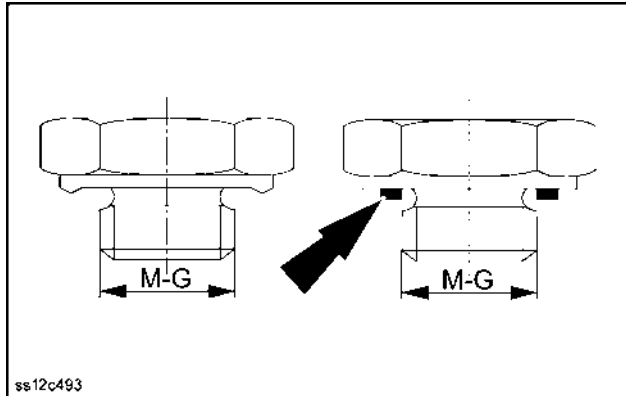

ss12c493

SS12C493 1